

## USAG 518 S6V

### Carrello SPRINT

#### SPRINT roller cabinet

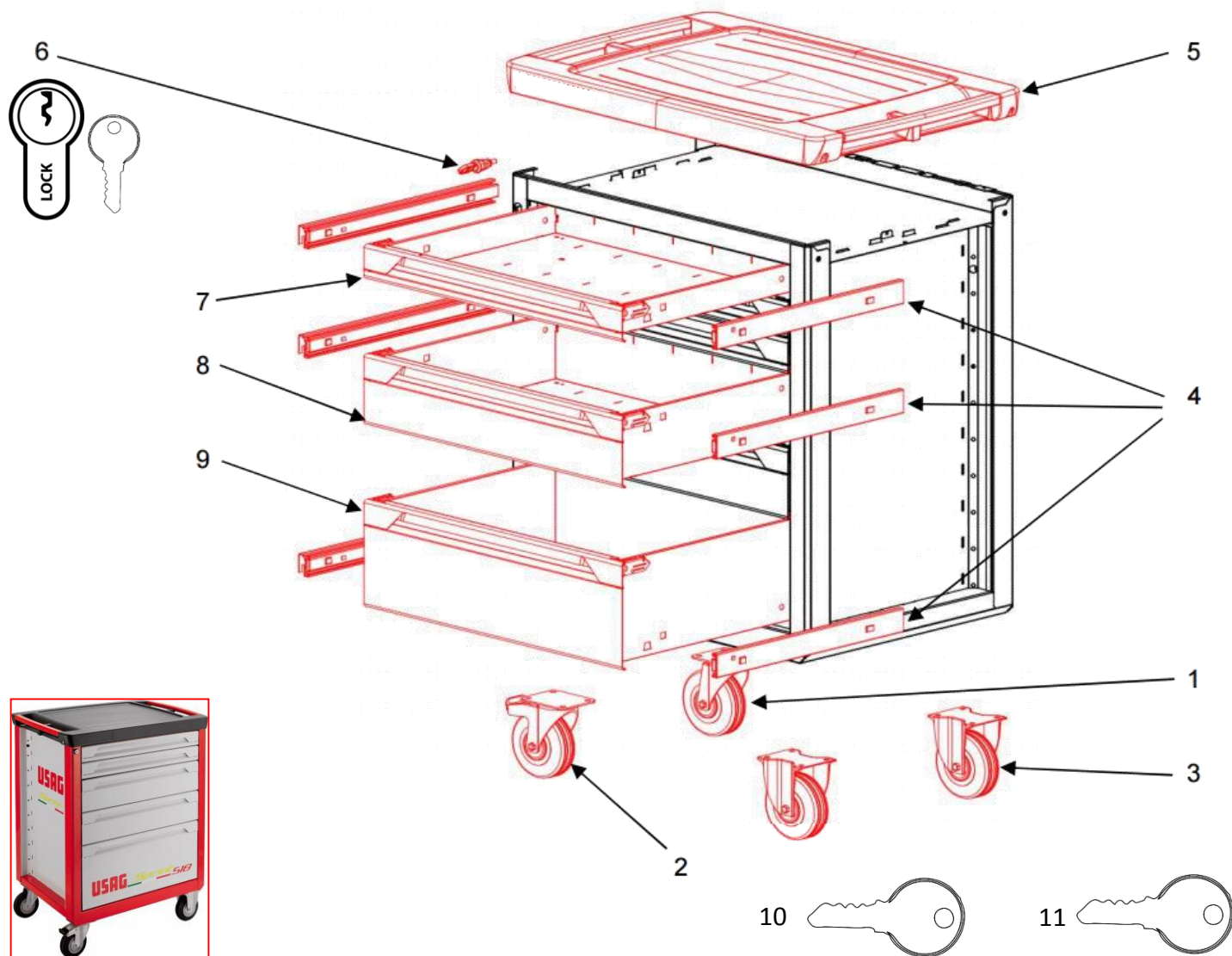

ITEM	CODICE/CODE	DESCRIZIONE	DESCRIPTION	QTY
1	U05190092Q	RUOTE PIVOTTANTE Ø 125 MM	SWIVEL WHEEL Ø 125 MM	1
2	U05190093Q	RUOTA PIVOTTANTE CON FRENO Ø 125 MM	SWIVEL WHEEL WITH BRAKE Ø 125 MM	1
3	U05190091Q	RUOTA FISSA Ø 125 MM	FIXED WHEEL Ø 125 MM	1
4	U05190512Q	SET DI 2 GUIDE	SET OF 2 SLIDES	2
5	U05190070Q	SERRATURA	LOCK	1
6	U05180021Q	PIANO DI LAVORO	WORKTOP	1
7	CHR5.02	CASSETTO (h 60 mm)	DRAWER (h 60 mm)	1
8	CHR5.03	CASSETTO (h 130 mm)	DRAWER (h 130 mm)	1
9	CHR5.05	CASSETTO (h 270 mm)	DRAWER (h 270 mm)	1
10	U05190068Q	CHIAVE PASSEPARTOUT	PASSEPARTOUT KEYS	1
11	U05190071Q	CHIAVI CON NUMERO SERIALE (SU RICHIESTA)	KEYS WITH SERIAL NUMBER (BY REQUEST)	1

**Cassetti forniti senza: guide (4)**  
**Drawers without: Slides (6)**